

INSTALLATION INSTRUCTIONS

1. Use the existing mounting nuts and washers, or replace, as indicated by condition. Torque the nuts to tightening torque indicated in TCM Engine Overhaul Manual (typically 275-325 In. Lb.).
2. Remove the nut and internal-tooth lockwasher from the Power Lead bolt. Put the power cable terminal over the Power Lead bolt, followed by the internal-tooth lockwasher and the nut. Hold a backup on the lower nut and torque the top nut to 50 In. Lb. Do not over-torque. Place insulating nipple over terminal connection.
3. A Rotation Inspection Port is located over the clutch drum for the purpose of establishing whether the starter motor is turning the engines starter adapter. There are no field repairable components in this unit.

REVISIONS

LTR.	DESCRIPTION	DATE	APRV.
A	ADDED NOTE 3, CHANGE NOTE 2	12/17/03	EC
B	CORRECTED VIEW & DIMENSIONS	10/30/08	EC

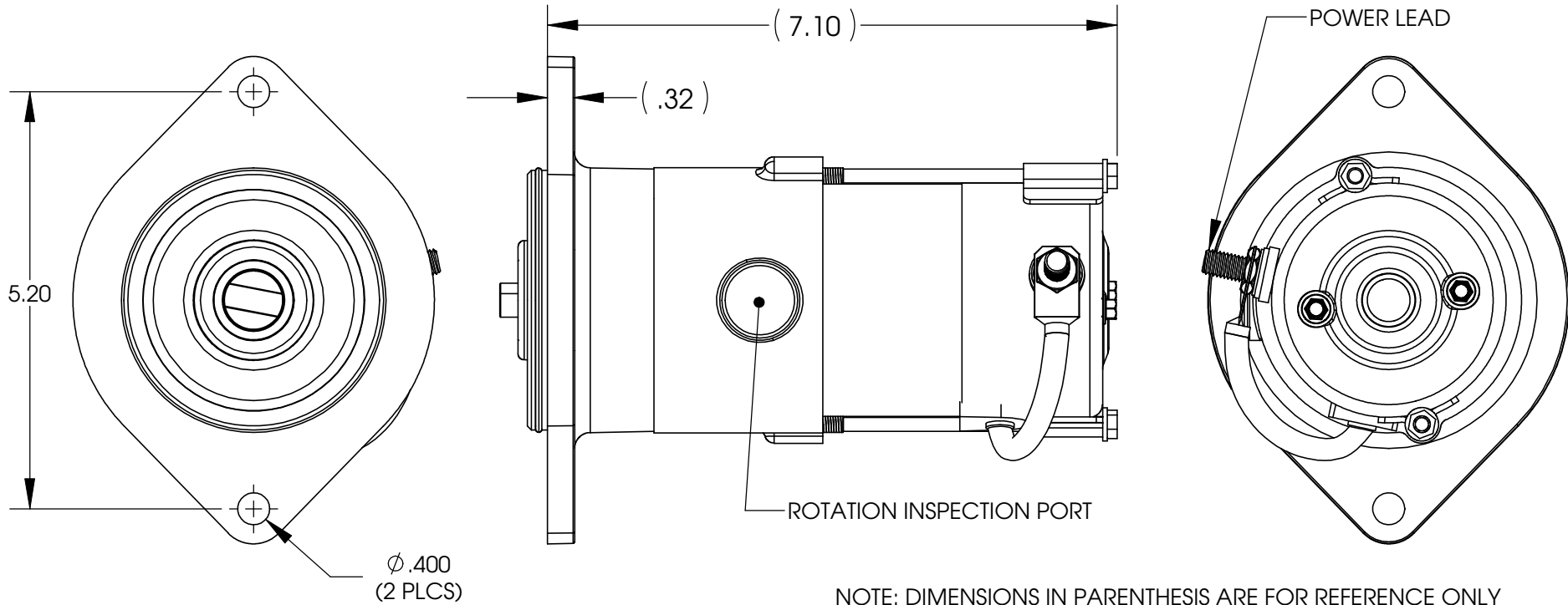

NOTE: DIMENSIONS IN PARENTHESIS ARE FOR REFERENCE ONLY

PMA MARKINGS

Sky-Tec FAA-PMA	
Eligible on: Continental O-300-D, O-300-E, IO-360, TSIO-360, LTSIO-360, O-470, IO-470, IO-520, LIO-520, TSIO-520, GTSIO-520, LTSIO-520, IO-550 & TSIO-550 Engines.	
Model No.	Serial No.
C12ST3	2C3-9909«N»
Rev <input type="text" value="D"/>	Volts <input type="text" value="12"/>

Sky-Tec FAA-PMA	
Eligible on: Continental O-300-D, O-300-E, IO-360, TSIO-360, LTSIO-360, O-470, IO-470, IO-520, LIO-520, TSIO-520, GTSIO-520, LTSIO-520, IO-550 & TSIO-550 Engines.	
Model No.	Serial No.
C24ST3	4C3-9909«N»
Rev <input type="text" value="D"/>	Volts <input type="text" value="24"/>

Sky-Tec Partners, Ltd.	
Grandbury, Texas	
C12ST3/C24ST3 INSTALLATION INSTR.	
DRAWN BY:	DATE
E. CHIAPPE	9/02/03
MATERIAL	DWG. NO.
	30001
REV.	B